

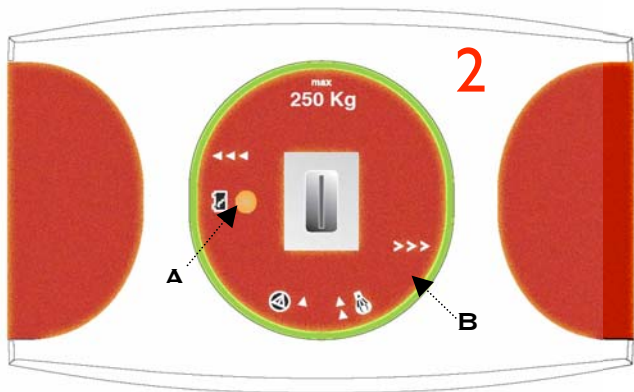
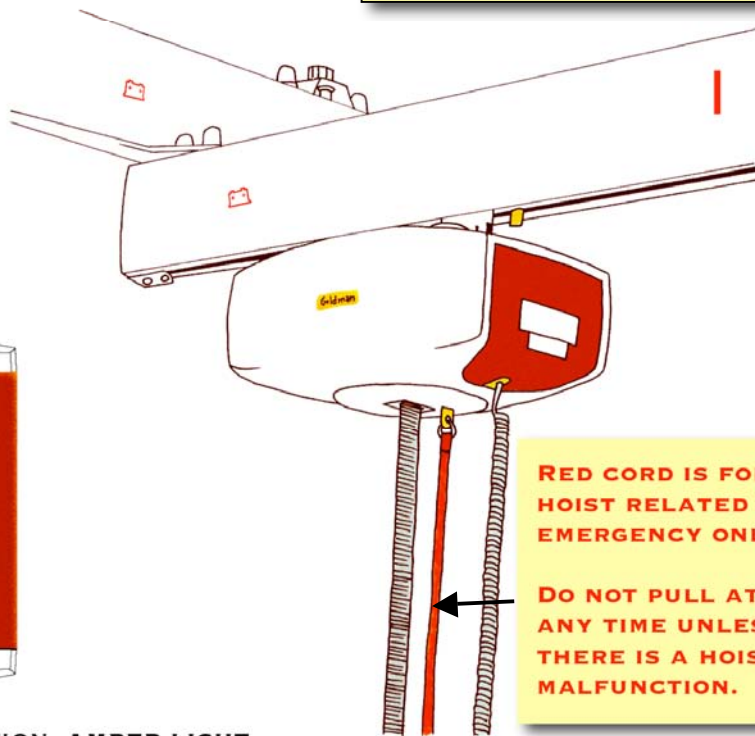
# GH2HD Ceiling Hoist System- with Charging Station

SWL 272 Kg/ 600 lbs\*


**FIG 1.** WHEN THE TRANSFER IS COMPLETE, WALK THE HOIST USING THE HANGER BAR BACK TO THE PARKING STATION INDICATED BY THE BATTERY SYMBOLS. 

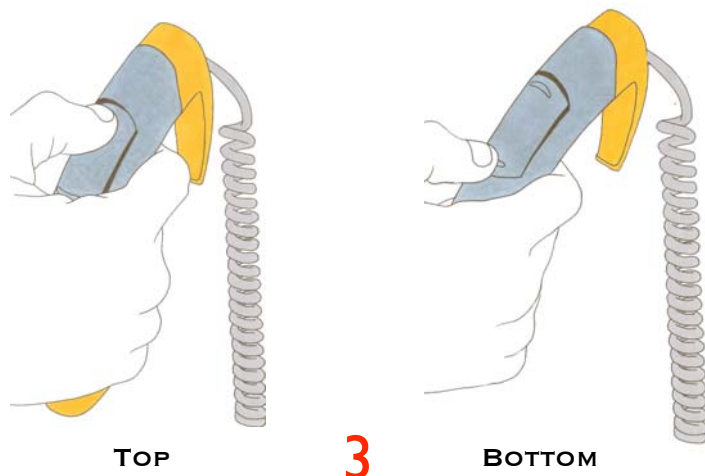
THE HOIST WILL BEGIN TO AUTOMATICALLY CHARGE THE BATTERIES.

\*HOIST IS CERTIFIED TO 272 KG (600 LBS) EVEN WHEN LABELED AS 250 KG (550 LBS).



**FIG 2.** WHEN HOIST IS BACK TO PARKING STATION, AMBER LIGHT (A) TURNS ON INDICATED HOIST IS BEING CHARGED. LIGHT TURNS OFF WHEN HOIST FULLY CHARGED.

**GREEN GLOW LIGHT (B)-** IS ON WHEN HOIST IS BEING USED. IT SHUTS OFF WHEN HOIST IS NOT IN USE AFTER 45 SECONDS. IF GREEN LIGHT BLINKS- THIS INDICATES LOW BATTERY- COMPLETE YOUR TRANSFER AND THEN DOCK THE HOIST IN THE DOCKING AREA INDICATED BY THE BATTERY SYMBOLS. 

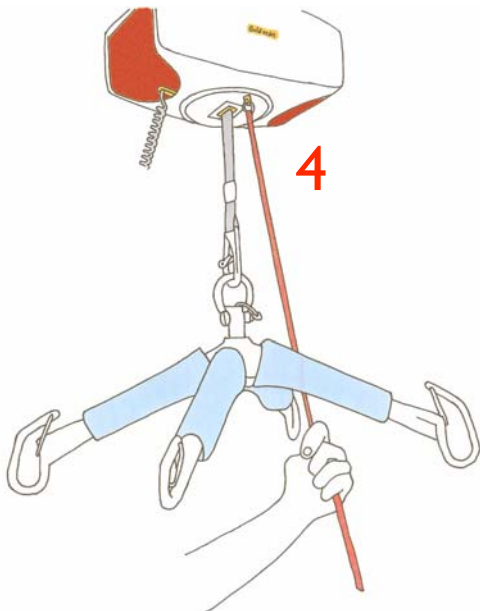


**FIG 3. HANDSET OPERATION**

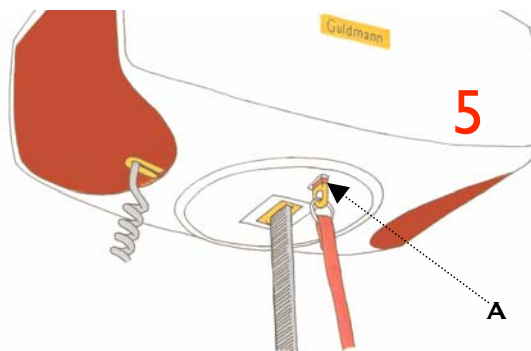
- PRESS TOP OF TOGGLE SWITCH TO RAISE THE HANGER BAR. PRESS BOTTOM TO LOWER THE HANGER BAR.
- IF THE HOIST MOTOR IS OFF, PRESS EITHER TOP OR BOTTOM TWICE TO TURN THE MOTOR BACK ON.

**EMERGENCY FEATURES**

**IF HANDSET FAILS OR LIFT STOPS WORKING WITH PATIENT IN SLING**

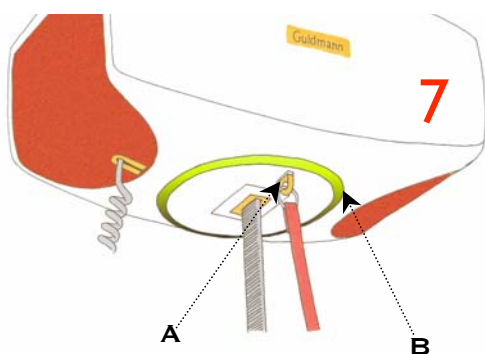


**FIG 4. EMERGENCY STOP.** IN THE EVENT OF HANDSET MALFUNCTION - EITHER THE BUTTONS STICK OR ARE NOT RESPONSIVE- PULL THE RED CORD ONCE UNTIL YOU HEAR A CLICK.



**FIG. 5.** THE YELLOW TAB (A) AT THE END OF THE CORD SHOULD SHOW A RED BAND. THIS STOPS ALL ACTIONS WITH THE HOIST. REPORT THE ISSUE TO FACILITIES FOR REPAIR.

**FIG 6. EMERGENCY LOWER-** IF THE HOIST FAILS WHILE YOU HAVE A PATIENT IN THE SYSTEM, DETERMINE WHERE TO SAFELY LOWER YOUR PATIENT, THEN PULL AND CONTINUE TO PULL THE RED CORD, THE SYSTEM WILL SLOWLY LOWER THE PATIENT. RELEASING THE PULL ON THE CORD AT ANY TIME STOPS THE PROCESS.



**FIG 7.** IF THE RED CORD HAS BEEN PULLED, YOU MUST RESET THE HOIST. PUSH YELLOW TAB (A) UNTIL YOU HEAR A CLICK. TO TURN HOIST ON, PRESS HANDSET TOGGLE SWITCH UNTIL GREEN GLOW LIGHT (B) COMES ON.

**YELLOW TAB MUST BE PUSHED IN WHEN CHARGING THE HOIST**

