

## The LiftSeat<sup>®</sup> 300 Toilet Lift For Acute Care

LiftSeat introduces a new way to assist patients and residents with the daily task of toileting – the LiftSeat<sup>®</sup> 300 toilet lift. LiftSeat is the no-lift, no-store, on-demand solution for supporting one of the most repetitive, biomechanically challenging activities of daily living (ADL).

### LiftSeat<sup>®</sup> 300 Features



- 1** Built-in controls with anti-slip grip enhancement move unit up or down with the touch of a thumb.
- 2** Seamless, built-in splash guard reduces the chance of accidents and keeps the area around toilet clean.
- 3** Ergonomic, compact design features anti-fungal / antibacterial surface area.
- 4** Application of biomechanical analysis, kinematic studies, and human factors delivers optimal support of the sit-to-stand (STS) motion path.
- 5** Compact unit fits in most bathroom spaces and wheels easily from room to room.
- 6** 24V motor uses an easy-to-change, long-life rechargeable battery to eliminate safety and power source issues found in many bathrooms. Optional hard-wired configuration also available.
- 7** Separate handheld controller gives caregivers the ability to operate the lifting process at all times.
- 8** Seat design ensures easy cleaning and comfortable toileting experience.



**Installation is simple, secure and safe.**  
**Contact LiftSeat or your LiftSeat business partner for a free pre-installation checklist.**



LiftSeat Product Line	Product Number	Product Description
LiftSeat 300 Pro	LS-300-AP-110	AC unit w/o integrated up/down switch
LiftSeat 300 Pro BP	LS-300-AP-210	Battery power w/o integrated up/down switch
LiftSeat 300 Pro Plus	LS-300-AP-111	AC unit with integrated up/down switch
LiftSeat 300 Pro Plus BP	LS-300-AP-211	Battery power with integrated up/down switch

# General Dimensional Specifications

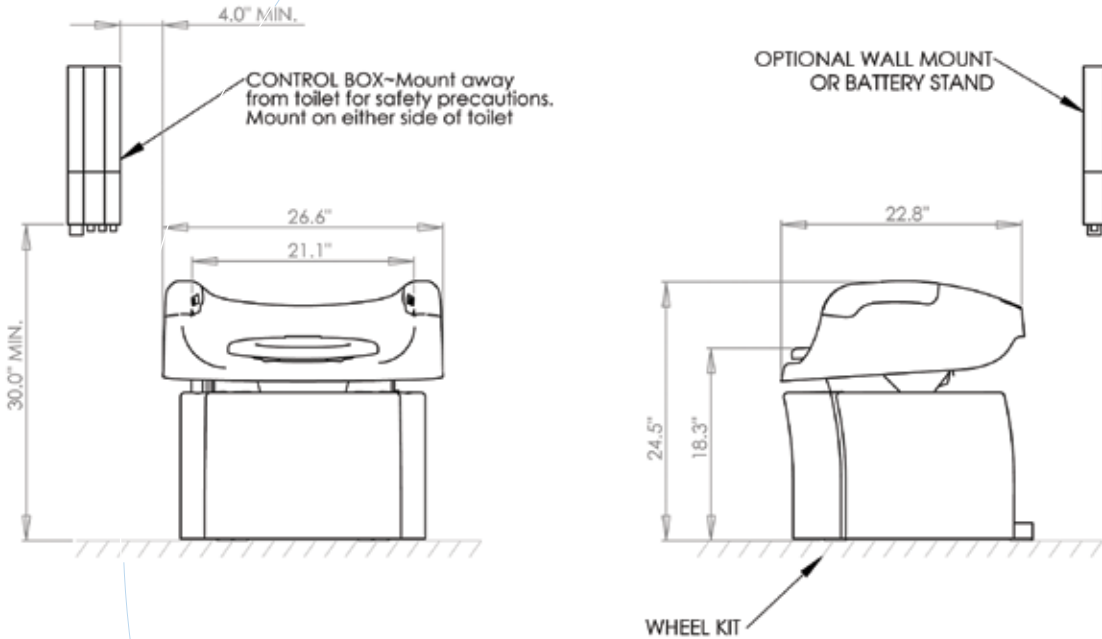

## **LiftSeat 300 Maximum Patient Load = 300 lbs.**

LiftSeat 300 mounts easily to the existing toilet for safety and stability. Shrouds can be removed for easy cleaning.

## **Linear Actuator**

Lead screw drive 24V DC motor, 4 Amp full load current, IP 66 rated, noise level 48dB.

## **Hard Wire Option**

Control Box (Hard Wired) – 24V DC output voltage (to motor), main input voltage 110-120V AC, (medically approved). Should be connected to a GFI outlet.

## **Battery Option**

Control Box (Battery Unit) – 24V DC output voltage, IP 65 rated, acoustic battery alarm @ 50% usage, Optional LCD display showing battery capacity and recharging indicator, battery stand.

## **Battery – High Capacity**

24V DC battery, 1 x 2.9 A, IP 65 rated (medically approved).

## **Charging Unit**

Four-hour charging cycle after initial 24-hour charge, main input voltage 110-120V AC (battery charging unit should not be used in a bathroom environment).

## **Handheld Remote and Integrated Hand Switches**

100mA per channel, IP 66 rated, high-strength plastic housing. Integrated hand switches can be disengaged for caregiver safety control.

**Talk with your LiftSeat business partner today**  
about purchase options for your facility.

## **LiftSeat Corporation**

158 Eisenhower Lane South  
Lombard, Illinois 60148

877-NOLIFT1

[www.liftseat.com](http://www.liftseat.com)